

LETS MAKE  
ZERO-EMISSION REAL

RentalMatch.eu

RentalMatch Green Power  
Dealer & Partner of JMG Cranes

Sales & Service Office  
Ecologieweg 16  
3343 LM Hendrik-Ido-Ambacht - Netherlands  
+31 (0) 78 204 92 60  
info@rentalmatch.eu

Gijs van de Graaf  
+31 651855113

Dick van de Graaf  
+31 613214166

Production Plant  
Via Sito Nuovo 14  
29010 Sarmato (PC) - Italy



vca✓

**RentalMatch**  
GREEN POWER

Electric  
Pick & Carry  
Cranes

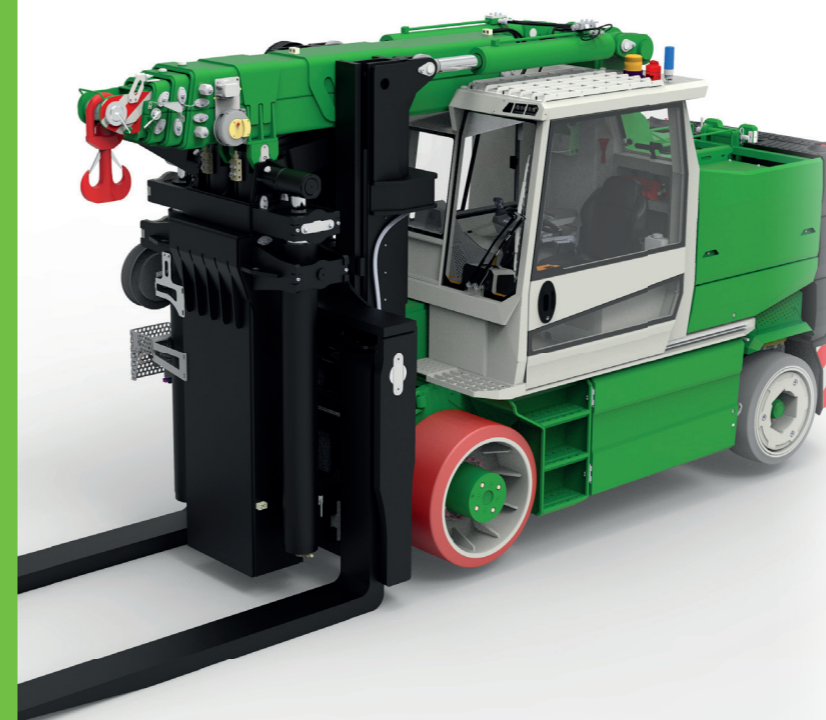

**MC 250.09FL (metric)**

Max Capacity hydraulic forks  
25t@0.9m

# MC 250.09FL

- ✓ Rear group with two independent rotation groups, winch and other accessories
- ✓ Front wheels drive with counterrotation
- ✓ Mast free lift
- ✓ Removable counterweights
- ✓ Removable group

### Options:

- Hydraulic crane boom with
- Electronic safe load indicator and tilting moment limiter
- Non marking tires
- Radio remote control
- Atex conversions
- Customized painting



### Technical features

Forks with extended group	25t@0.9m
Forks with retracted group	16.5t@0.9m
Dimensions	4120x1800x2750 mm

Front-wheels drive. N°2 electric motors AC 12 kW 96V	Hydraulically foot controlled service brake on all wheels, hydraulically automatic or button controlled parking brake on front wheels
Total with forks Kg. 25.000 Total with crane boom Kg. 27.500	Fabricated from preformed and welded quality steel plate
Weight support and fork length Kg. 3.000 Crane boom weight Kg. 3.000 Removable ballasts weight Kg. 6.000	Mast angle inclination +12°/-7°
96 V - 1050 Ah	N° 1 electric motor AC 35kW 96V
Front 800x674 in polyurethane cushion rear wheels: nr 4 in cushion 28x10x22	
Steering -90°/+90°	

### Load charts

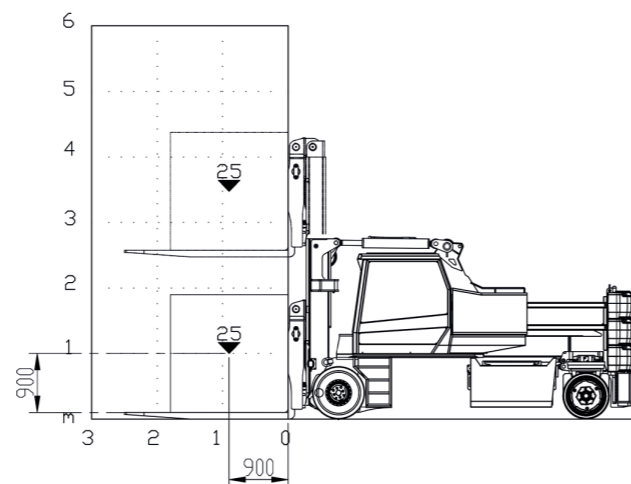

BOOM CAPACITY ON THE MAST - ALL COUNTERWEIGHTS - RETRACTED GROUP

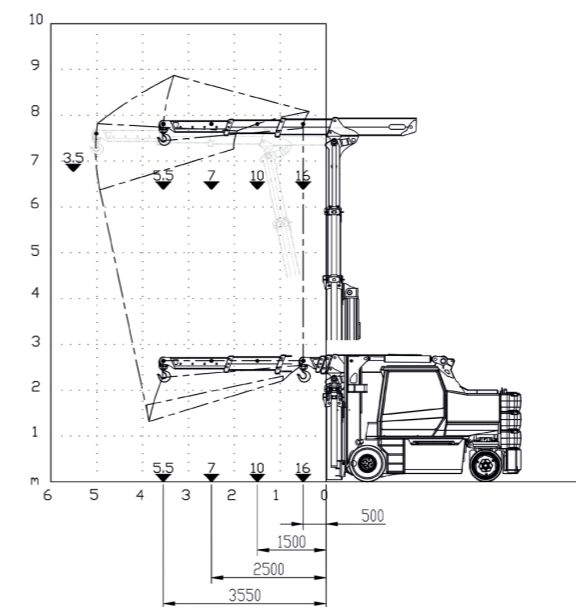

BOOM CAPACITY ON THE MAST - ALL COUNTERWEIGHTS - RETRACTED GROUP

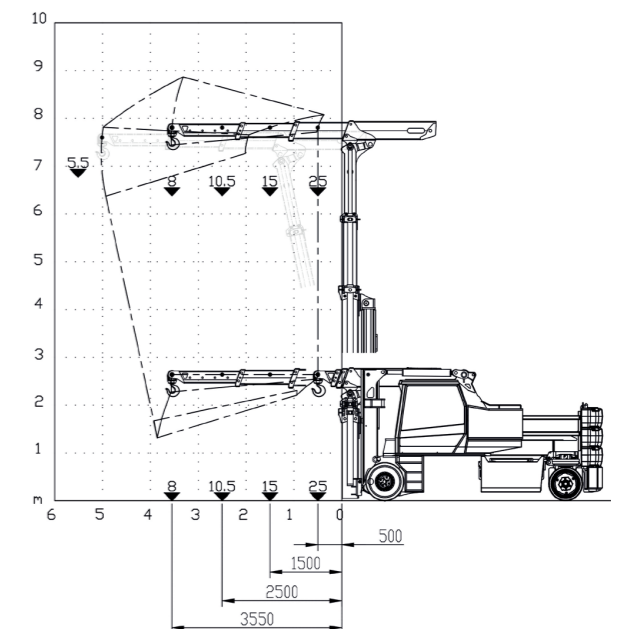

### EU Standards CE

	EN 13000:2014 WITH HYDRAULIC BOOM
	EN 22915:2022 EN 3691:2015 and subsequent modifications

### Dimensions

